

Description



The HX series hinge switches from Pizzato Elettrica combine safety and style in a single product.

The electric switch is fully integrated into the mechanical hinge so that it is virtually invisible to an inexperienced eye. This, besides being an aesthetic advantage, guarantees greater safety as a switch which is difficult to identify is consequently even more difficult to tamper with. The rear mounting without screws in sight and the very precise line mean the switch can be perfectly integrated even with guards of machinery with a very precise design.

As the HX series safety hinge switches are in stainless steel, they can be used in environments where particular attention must be paid to hygiene making them suitable for a variety of applications, ranging from the food and pharmaceutical sectors to the chemical and marine sectors.

Maximum safety with a single device

PL e + SIL 3

The HX BEE1 series hinge switches are constructed with redundant electronics. As a result, the maximum PL e and SIL 3, safety levels can still be achieved through the use of a single device on a guard. This avoids expensive wiring in the field and allows faster installation. Inside the control cabinet, the two electronic safety outputs must be connected to a module suitable for managing devices with solid state outputs, or to a safety PLC.

Series connection of several switches

PL e + SIL 3

One of the most important features of the HX series is the possibility of connecting up to 32 sensors in series, while still maintaining the maximum safety levels PL e laid down in EN 13849-1 and SIL 3 acc. to EN 62061.

This connection type is permissible in safety systems which have a safety module at the end of the chain that monitors the outputs of the last HX switch.

The fact that the PL e safety level can be maintained even with 32 sensors connected in series demonstrates the extremely secure structure of each single device.

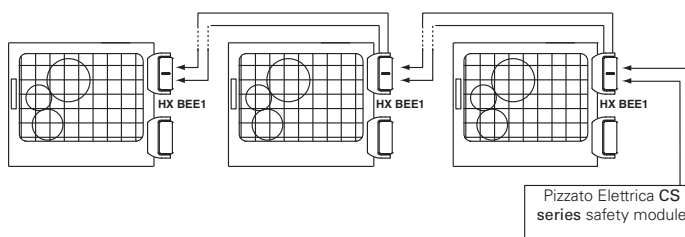

Series connection with other devices

PL e + SIL 3

The HX BEE1 series hinge switch features two safety inputs and two safety outputs, which can be connected in series with other Pizzato Elettrica safety devices. This option allows the creation of safety chains containing various devices. For example, stainless steel safety hinges (HX BEE1 series), transponder sensors (ST series) and door lock sensors (NG series) can be connected in series while still maintaining the maximum PL e and SIL 3 safety levels.

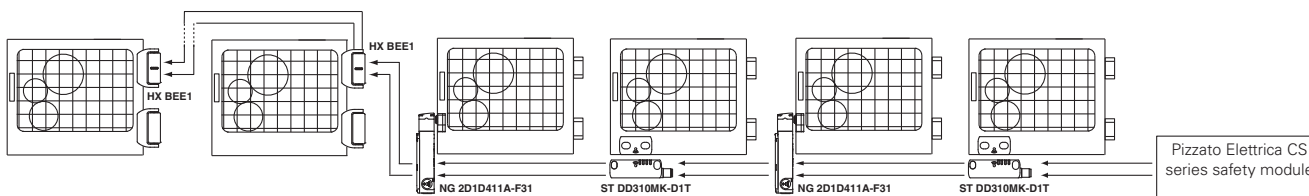

Adjustment of the switching point

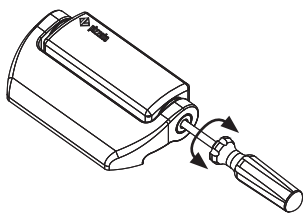

The switching point of the switches can be set with a screwdriver.

Adjusting the switching point allows for any calibration for large size guards. After calibrating the switch, it is always necessary to close the hole using the safety cap supplied.

Basic activation angle variants

On request, versions with a switch base activation angle of 15° multiples (e.g. 45° or 90°) are available.

The different activation angle does not exclude the possibility of fine adjustment of the switching point by means of the adjustment screw in the switch. Any change in the base operating angle does not alter the maximum mechanical switch travel.

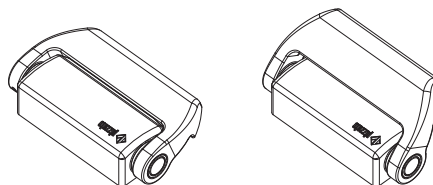

Cable with connector at the back

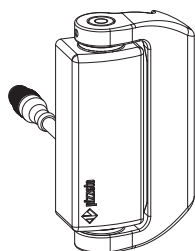

The version with a cable with M12 connector at the back offers the best combination of aesthetics and simple connection.

This solution allows the wiring to be hidden. At the same time, it facilitates the connection and disconnection of the wiring from inside the machinery.

Opening angle up to 180°

The mechanical design of the switch also allows use on guards with an opening angle of up to 180°.

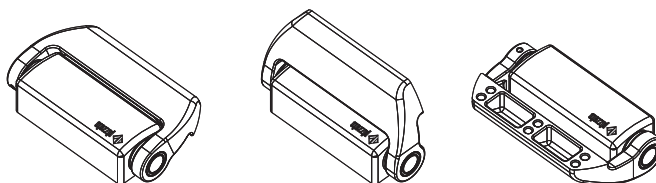



Protection degrees IP67 and IP69K

IP69K IP67

These devices are designed to be used in the toughest environmental conditions and they pass the IP67 immersion test acc. to EN 60529. They can therefore be used in all environments where maximum protection degree of the housing is required. Due to

their special design, these devices are suitable for use in equipment subjected to cleaning with high pressure hot water jets. These devices meet the IP69K test requirements according to ISO 20653 (water jets with 100 bar and 80°C).

Materials

AISI 316L

With this new series in AISI316L stainless steel, Pizzato Elettrica offers an extensive range of devices suitable for environments where special attention must be paid to cleanliness and hygiene.

The accurate surface finish allows these devices to be used for a variety of applications, ranging from the food and pharmaceutical sectors to the chemical and marine sectors.

For heavy duty applications

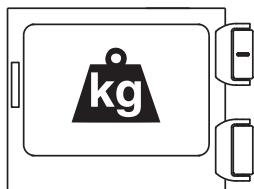

Specially designed for heavy industrial applications, these hinges are made of high-thickness microfusion materials with high strength mechanical properties. The maximum loads indicated in the technical specifications are those that the hinge can withstand without any lubrication, for one million opening and closing cycles,

while maintaining its features as a safety device in perfect efficiency.

With cable or connector

The electrical connection via integrated cable or M12 connector option makes the device suitable for the most diverse applications. The connector versions allow faster device replacement and installation, by making incorrect wiring connection impossible. The cable versions, on the other hand, offer the best value for money. Both the cable as well as the connector versions are available with mechanical or electronic contact blocks.

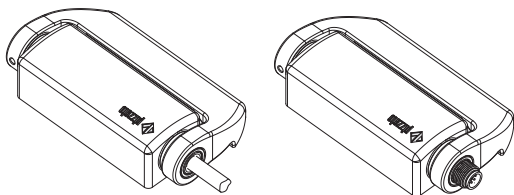

Three different output directions

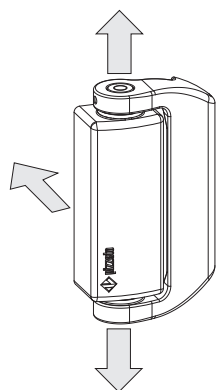

Designed for flexibility, the HX series safety hinges are equipped with three different output directions for the electrical conductors. Directions from below or from above allow the same exit direction of the conductor to be maintained, both for right and for left-hand doors. The direction from behind has the ultimate aesthetic, cleanliness and hygiene result. All three electrical output directions are available with output cables in various lengths or with M12 connector.

Additional hinges

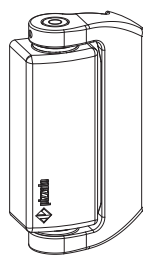

To complete the installation, various types of additional hinges are available to be used in a variable number depending on the weight of the guard.

These hinges have the same aesthetic and mechanical structure but cost less as they contain no electrical parts.

Laser engraving



Pizzato Elettrica has introduced a new laser engraving system for stainless steel switches of the HX series.

Thanks to this new system, engravings on the products are indelible.

Mechanical or electronic contact blocks

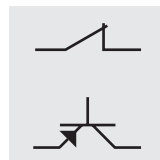

Internally equipped with innovative concepts, the HX series safety switches can be supplied both with electromechanical safety contacts with positive opening, or with self monitoring redundant electronic safety outputs. This allows the customer to choose between the most cost-effective solution (mechanical contacts) or a maximum security solution (electronic outputs).

Four LEDs for immediate diagnosis



The versions with electronic contact block are equipped with four signalling LEDs. Each LED represents a specific hinge function, this greatly facilitates switching point adjustment via the immediate visual indication for the installer during the adjustment phase. There are also three separate LEDs available: one for input status, one for output status, and one for general device status. For serial applications,

this independence enables identification of any interruptions in the safety chain and of any internal errors. All of this at a glance, without needing to decode complex flashing sequences.

Gold-plated contacts

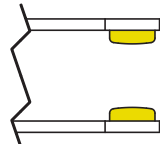

The contact blocks of these devices can be supplied gold-plated upon request. Ideal for applications with low voltages or currents; it ensures increased contact reliability. The high-thickness coating > 1 micron ensures the mechanical endurance of the coating over time.

Selection diagram

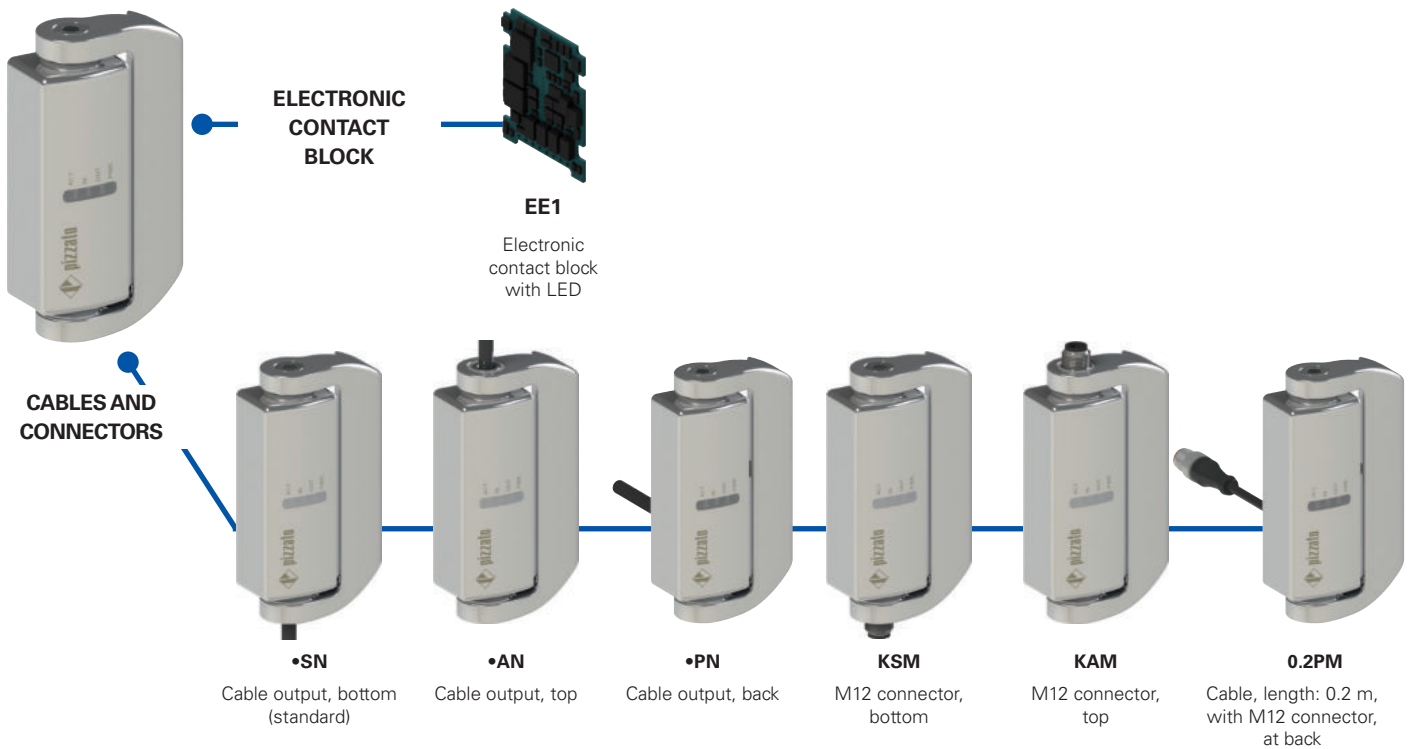
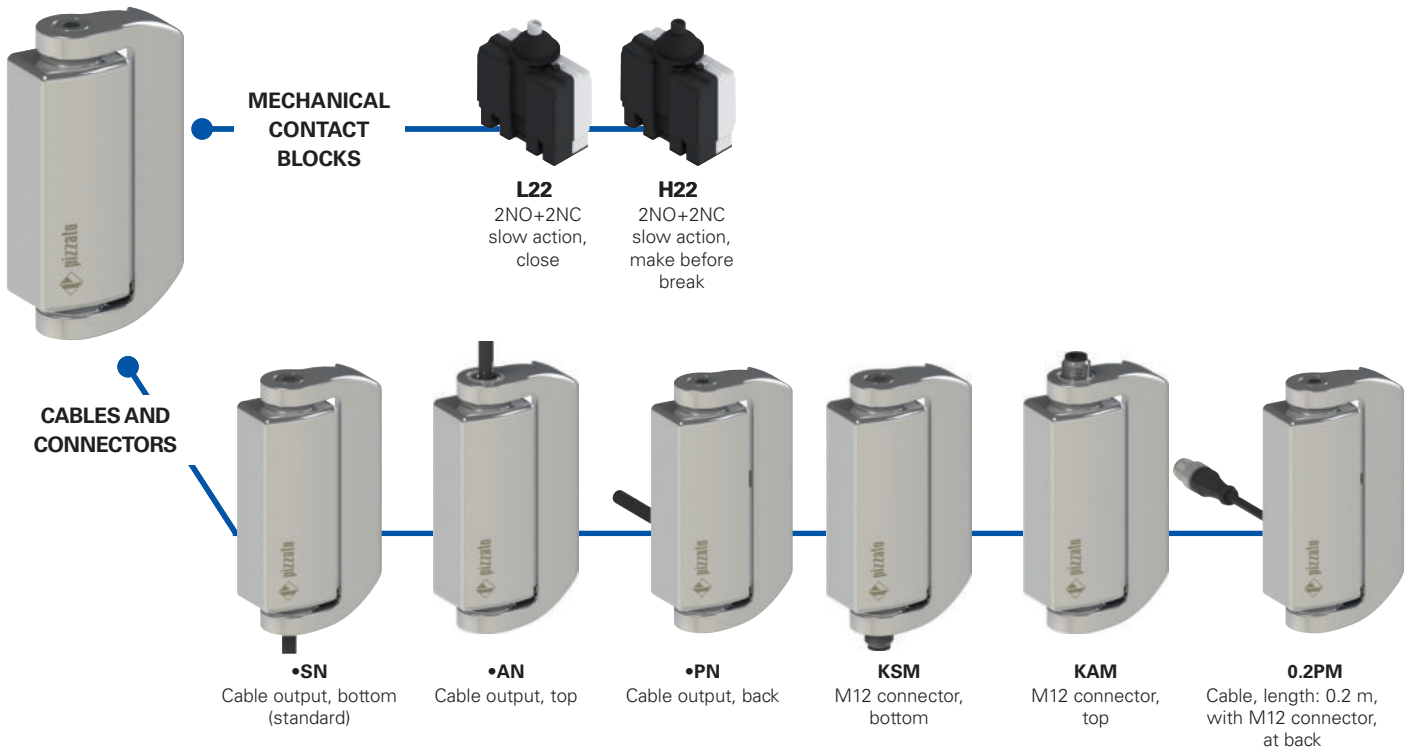

ADDITIONAL HINGES



HX CB

HX CD

—●— product option

**Code structure****Attention!** The feasibility of a code number does not mean the effective availability of a product. Please contact our sales office.

article	options
HX BL22-2PN	GH15

Body and movable part dimensions	
B	126x76x31 mm

Contact block	
L22	2NO+2NC, slow action, close
H22	2NO+2NC, slow action, make before break
EE1	electronic contact block with LED 2 PNP safety outputs 1 PNP signalling output 2 PNP safety inputs

Connection type	
0.2	cable, length: 0.2 m (available for 0.2 PM versions only)
0.5	cable, length: 0.5 m
...
2	cable, length: 2 m (standard)
...
10	cable, length: 10 m
K	with integrated connector

Other cable lengths on request.

Activation angle	
	0° activation angle (standard)
H15	15° activation angle
H30	30° activation angle
H45	45° activation angle
H60	60° activation angle
H75	75° activation angle
H90	90° activation angle
H345	345° activation angle

Contact type	
	silver contacts (standard)
G	silver contacts with 1 µm gold coating

Cable or connector type	
N	PVC cable, IEC 60332-1-2 oil-resistant
M	cable with M12 connector

Output direction, connections	
S	movable part at the right and bottom output
P	movable part at the right and output at the back
A	movable part at the right and output at top
Q	movable part at the left and output at the back (on request)

Code structure for additional hinges

article	options
HX CB	-V46

Additional hinges	
CB	126x76x31 mm, movable part at the right
CD	126x76x31 mm, movable part at the left

Ground connection	
	with no ground connection between the fixed part and the moving part (standard)
V46	with ground connection between the fixed part and the moving part



Main features

- AISI 316L stainless steel housing
- Protection degrees IP67 and IP69K
- Electronic contact block with LED
- Versions with M12 connector
- Additional hinge without contacts

Quality marks:



EC type examination certificate: M6A 075157 0030
 UL approval: E131787
 TÜV SÜD approval: Z10 075157 0028
 EAC approval: RU C-IT.YT03.B.00035/19

In compliance with standards:

IEC 60947-5-1, EN 60947-5-1, EN 60947-1,
 IEC 60204-1, EN 60204-1, EN ISO 14119,
 EN ISO 12100, IEC 60529, EN 60529, ISO 20653,
 IEC 61508-1, IEC 61508-2, IEC 61508-3,
 EN ISO 13849-1, EN ISO 13849-2, EN 62061,
 EN 61326-1, EN 61326-3-1, EN 61326-3-2,
 EN IEC 63000, UL 508, CSA 22.2 No.14

Compliance with the requirements of:

Machinery Directive 2006/42/EC,
 EMC Directive 2014/30/EU,
 RoHS Directive 2011/65/EU.

Positive contact opening in conformity with standards:

IEC 60947-5-1, EN 60947-5-1.

Technical data

Housing

Metal housing, polished, AISI 316L stainless steel
 Versions with integrated cable, length 2 m, other lengths from 0.5 ... 10 m on request
 Versions with integrated M12 connector
 Versions with M12 connector and 0.2 m cable, other lengths from 0.1 ... 3 m on request

Protection degree: IP67 acc. to EN 60529
 IP69K acc. to ISO 20653
 (Protect the cables from direct high-pressure and high-temperature jets)

Corrosion resistance in saline mist: ≥ 1000 hours in NSS acc. to ISO 9227

General data

SIL (SIL CL) up to: SIL CL 3 acc. to EN 62061
 Performance Level (PL) up to: PL e acc. to EN ISO 13849-1
 Mechanical interlock, not coded: type 1 acc. to EN ISO 14119
 Safety parameters HX B•22-•••
 B_{10D} : 5,000,000 for NC contacts
 Safety parameters HX BEE1-•••
 $MTTF_D$: 2413 years
 PFH_D : 1.24E-09
 DC: High
 Mission time: 20 years
 Ambient temperature: see table on page 78
 Max. actuation frequency: 600 operating cycles/hour
 Mechanical endurance: 1 million operating cycles
 Max. actuation speed: 90°/s
 Min. actuation speed: 2°/s
 Mounting position: any
 Tightening torque, M6 screws: 10 ... 12 Nm

Electrical data (L22 - H22 mechanical contact blocks)

Rated impulse withstand voltage U_{imp} : 4 kV
 Conditional short circuit current: 1000 A acc. to EN 60947-5-1
 Pollution degree: 3

Electrical data (EE1 electronic contact block)

Rated operating voltage U_e : 24 Vdc -15% ... +10% SELV
 Consumption at voltage U_e : < 1W
 Rated impulse withstand voltage U_{imp} : 1.5 kV
 Resettable internal protection fuse: 1.1 A
 Overvoltage category: III
 IS1/IS2 safety inputs
 Rated operating voltage U_e : 24 Vdc
 Rated current consumption: 5 mA
 OS1/OS2 safety outputs
 Rated operating voltage U_e : 24 Vdc
 Output type: PNP type OSSD
 Utilisation category: DC13; $U_e=24$ Vdc; $I_e=0.25$ A
 Short circuit detection: Yes
 Overcurrent protection: Yes
 Duration of the deactivation impulses at the safety outputs: < 300 us
 Permissible capacitance between outputs: < 200 nF
 Permissible capacitance between output and ground: < 200 nF
 O3 signalling output
 Rated operating voltage U_e : 24 Vdc
 Output type: PNP
 Utilisation category: DC13; $U_e=24$ Vdc; $I_e=0.1$ A
 Short circuit detection: No
 Overcurrent protection: Yes

⚠ If not expressly indicated in this chapter, for correct installation and utilization of all articles see the instructions given on pages 377 to 392.

⚠ Important: Switch off the circuit voltage before disconnecting the connector from the switch. The connector is not suitable for separation of electrical loads. According to EN 60204-1, versions with 8-pole M12 connector can be used only in SELV circuits.

Features approved by UL

Electrical Ratings: R300 pilot duty (28 VA, 125-250 Vdc)
 C300 pilot duty (180 VA, 120-240 Vac)
 24 Vac, Class 2, 2 A pilot duty (M12 connector)
 24 Vdc, Class 2, 0.22 A pilot duty (M12 connector)
 24 Vdc / 0.25 A (electronic version)

Environmental Ratings: Types 1, 4X, 6, 12, 13

Please contact our technical department for the list of approved products.

Features approved by TÜV SÜD

Supply voltage: 24 Vdc
 Rated operating current (max.): 0.25 A
 Ambient temperature: -25°C ... +70°C
 Protection degree: IP67 and IP69K
 PL, category: PL e, category 4
 Response time to deactivation of contacts/inputs: maximum 12 ms

In compliance with standards: IEC 61508-1:2010 (SIL 3), IEC 61508-2:2010 (SIL 3), IEC 61508-3:2010 (SIL 3), IEC 61508-4:2010 (SIL 3), IEC 62061:2005/A2:2015 (SIL CL 3), EN ISO 13849-1:2015 (PL e, Cat. 4), EN 60947-5-1:2017, ISO 14119:2013

Please contact our technical department for the list of approved products.



Utilization temperatures and electrical data for L22/H22 mechanical contact blocks

		N type cable 9 x 0.34 mm ²	M12 connector, 8-pole	
Ambient temperature	Cable, fixed installation	-25°C ... +80°C	-25°C ... +80°C	
	Cable, flexible installation	-5°C ... +80°C	-5°C ... +80°C	
	Cable, mobile installation	/	/	
Electrical data	Thermal current I _{th}	3 A	2 A	
	Rated insulation voltage U _i	250 Vac	30 Vac 36 Vdc	
	Protection against short circuits (fuse)	3 A 500 V type gG	2 A 500V type gG	
	Utilization category DC13	24 V	2 A	2 A
		125 V	0.4 A	/
		250 V	0.3 A	/
	Utilization category AC15	24 V	3 A	2 A
		120 V	3 A	/
		250 V	3 A	/
Approvals	CE cULus TÜV EAC	CE cULus TÜV EAC		

Utilization temperatures and electrical data for EE1 electronic contact block

		N type cable 8 x 0.34 mm ²	M12 connector, 8-pole
Ambient temperature	Cable, fixed installation	-25°C ... +70°C	-25°C ... +70°C
	Cable, flexible installation	-5°C ... +70°C	-5°C ... +70°C
	Cable, mobile installation	/	/
Electrical data	Thermal current I _{th}	0.25 A	0.25 A
	Rated insulation voltage U _i	32 Vdc	32 Vdc
	Protection against short circuits (fuse)	1 A	1 A
	Utilization category DC13	0.25 A	0.25 A
	Approvals	CE cULus TÜV EAC	CE cULus TÜV EAC

Internal device connections

Mechanical contact blocks (HX B•22-•••)

Contacts	Versions with cable	Versions with M12 connector
NC	black	1
	black-white	2
NC	red	3
	red-white	4
NO	brown	5
	blue	6
NO	purple	7
	purple-white	8
⊥	yellow/green	/



Legend:

NC normally closed contact
 NO normally open contact
 ⊥ ground connection

Electronic contact blocks (HX BEE1-•••)

Connection	Versions with cable	Versions with M12 connector
A1	brown	1
IS1	red	2
A2	blue	3
OS1	red-white	4
O3	black	5
IS2	purple	6
OS2	black-white	7
not connected	purple-white	8



Legend:

A1-A2 supply
 IS1-IS2 safety inputs
 OS1-OS2 safety outputs
 O3 signalling output

Contact type
LA = slow action close
LO = slow action, make before break
EE1 = electronic, PNP

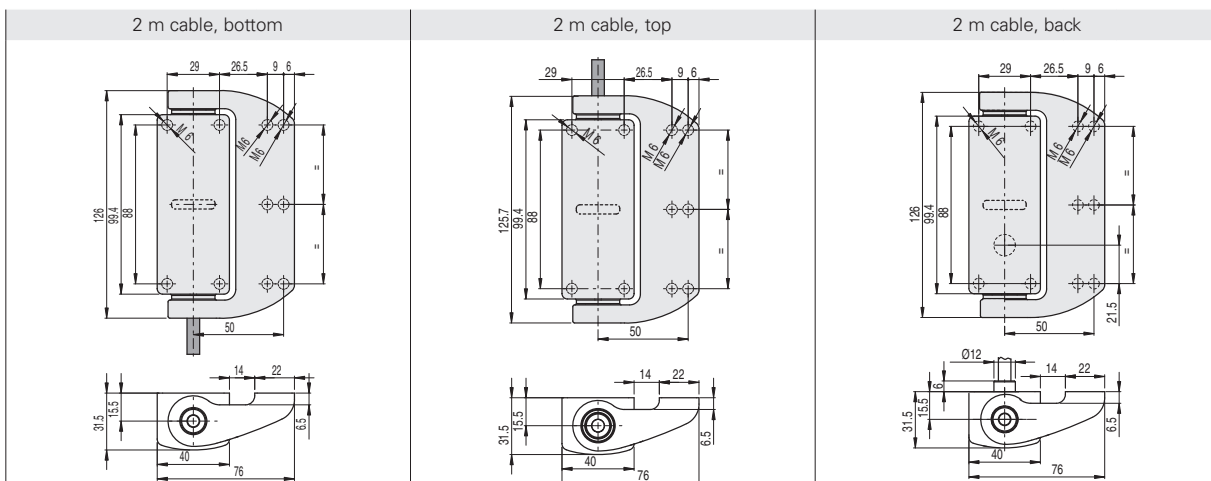

Contact block										
L22	LA	HX BL22-2SN	⊕	2NO+2NC	HX BL22-2AN	⊕	2NO+2NC	HX BL22-2PN	⊕	2NO+2NC
H22	LO	HX BH22-2SN	⊕	2NO+2NC	HX BH22-2AN	⊕	2NO+2NC	HX BH22-2PN	⊕	2NO+2NC
EE1	EE1	HX BEE1-2SN		PNP	HX BEE1-2AN		PNP	HX BEE1-2PN		PNP
Actuating force		0.3 Nm (0.65 Nm ⊕)			0.3 Nm (0.65 Nm ⊕)			0.3 Nm (0.65 Nm ⊕)		

Contact type
LA = slow action close
LO = slow action, make before break
EE1 = electronic, PNP

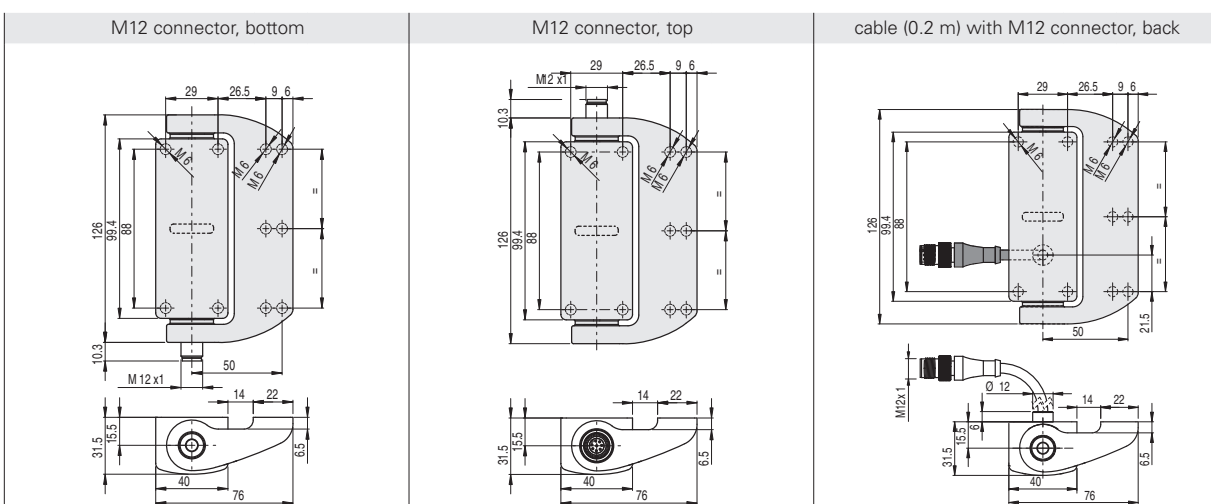

Contact block										
L22	LA	HX BL22-KSM	⊖	2NO+2NC	HX BL22-KAM	⊖	2NO+2NC	HX BL22-0.2PM	⊖	2NO+2NC
H22	LO	HX BH22-KSM	⊖	2NO+2NC	HX BH22-KAM	⊖	2NO+2NC	HX BH22-0.2PM	⊖	2NO+2NC
EE1	EE1	HX BEE1-KSM		PNP	HX BEE1-KAM		PNP	HX BEE1-0.2PM		PNP
Actuating force		0.3 Nm (0.65 Nm ⊕)			0.3 Nm (0.65 Nm ⊕)			0.3 Nm (0.65 Nm ⊕)		

To order a product with a movable part at the left replace P with Q in the codes shown above.
 Example: HX BL22-2PN → HX BL22-2QN

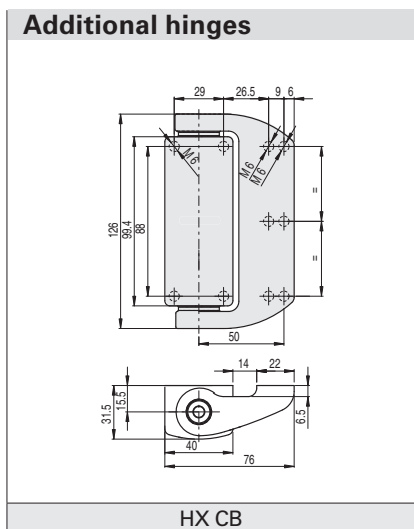

Travel diagrams

Contact block	Group 1
L22 2NO+2NC	
H22 2NO+2NC	
EE1 PNP	

The switching point of the contacts can be adjusted ± 1° compared to that indicated in the travel diagrams.
 The hinge is supplied without pre-adjustment.

Legend

 Closed contact /Outputs OS1, OS2, O3 active
 Open contact /Outputs OS1, OS2, O3 not active
 ⊕ Positive opening travel



Complete safety system

The use of complete and tested solutions guarantees the electrical compatibility between the hinge of the HX series and the safety modules from Pizzato Elettrica, as well as high reliability. The sensors have been tested with the modules listed in the adjacent table.

Switch	Compatible safety modules	Safety module output contacts		
		Instantaneous safety contacts	Delayed safety contacts	Signalling contacts
HX BEE1-•••	CS AR-05•••••	3NO	/	1NC
	CS AR-06•••••	3NO	/	1NC
	CS AR-08•••••	2NO	/	/
	CS AT-0••••••	2NO	2NO	1NC
	CS AT-1••••••	3NO	2NO	/
	CS MP•••••••	see page 309		
CS MF•••••••	see page 341			

The hinges with HX BEE1-••• electronic contact block can be connected to safety modules or safety PLCs with OSSD inputs provided compatibility is ensured in advance.

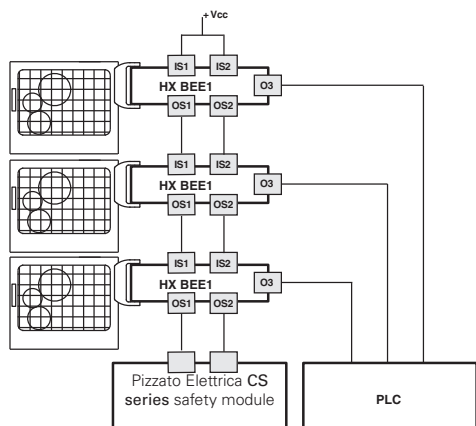

Possibility of series connection of multiple hinges for simplifying the wiring of the safety system, whereby only the outputs of the last hinge are evaluated by a Pizzato Elettrica safety module (see table with compatible safety modules). Each HX switch is provided with a signalling output, which is activated when the respective guard is closed. Depending on the specific requirements of the application, this information can be evaluated by a PLC.

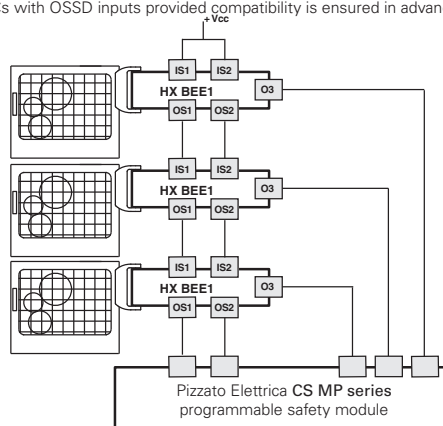

Possibility of series connection of multiple hinges for simplifying the wiring of the safety system, whereby only the outputs of the last hinge are evaluated by a Pizzato Elettrica safety module of the CS MP series. Both the safety-relevant evaluation and the evaluation of the signalling outputs are performed by the CS MP series.

Internal block diagram

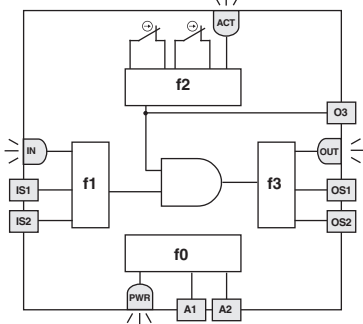

The adjacent diagram illustrates 4 logical, linked sub-functions of the hinge switch.

Function f0 is a basic function and includes the monitoring of the power supply as well as internal, cyclical tests.

The task of function f1 is to evaluate the status of the device inputs, whereas function f2 checks the opening of the guard. Function f3 is intended to activate or deactivate the safety outputs and check for any faults or short circuits in the outputs.

The safety-related function, which combines the sub-functions mentioned above, only activates the safety outputs if the input signals are correctly applied and the guard is in closed position.

The status of each function is displayed by the corresponding LED (PWR, IN, ACT, LOCK, OUT), in such a way that the general device status becomes immediately obvious to the operator.

LED	Function
ACT	state of actuator / O3 output
IN	status of safety inputs
OUT	status of safety outputs
PWR	Power supply/self-diagnosis

Series connection

To simplify series connections of the devices, various M12 connectors are available that allow complete wiring.

This solution significantly reduces installation times while at the same time maintaining the maximum safety levels PL e and SIL 3.

For further information see page 366.

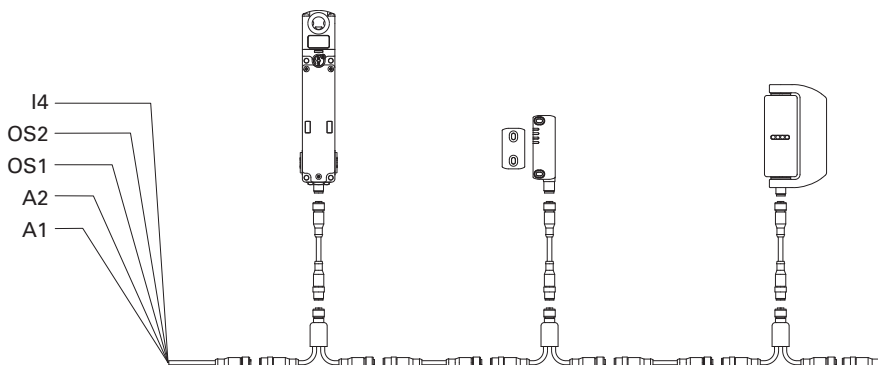

Accessories

Article	Description
VF AC7032	Protection cap of adjustment screw



The cap is supplied with every hinge and must always be attached after the fine adjustment of the switching point.

In case of loss or damage, the cap can be ordered separately.

Fixing plates

Article	Description
VF SFH10-TX	Couple of stainless steel plane plates supplied with fastening screws for attachment of the switch.

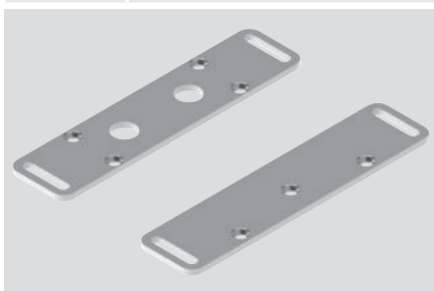

Article	Description
VF SFH9	Polyethylene gaskets for the food industry. Seals the contact surface between the hinge and the frame.

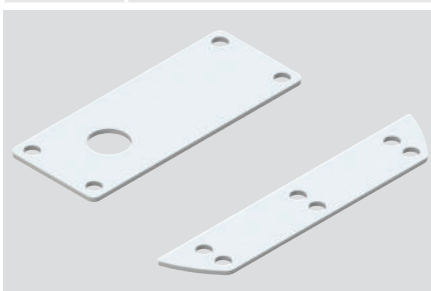

Article	Description
VF SFH8	Mobile part cover in stainless steel. Ideal for fixing the mobile part with polycarbonate guards.

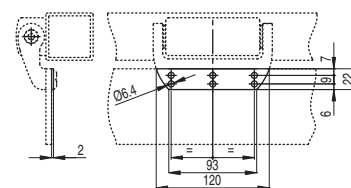
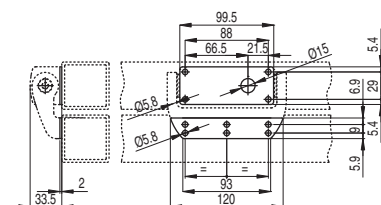
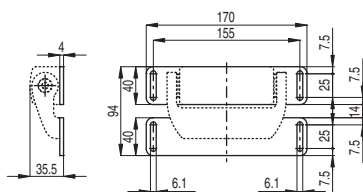
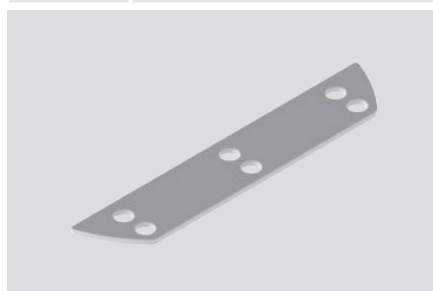

Max. forces and loads HX

Admitted max. loads, independent of utilization conditions.

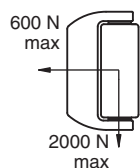

Attention: Never exceed the loads listed above under any circumstances.

The loads have been verified by a fatigue test of one million operating cycles with a 90° opening angle.

Doors with one safety hinge
 $F_{max} (N) = 50,000/D$ (mm)

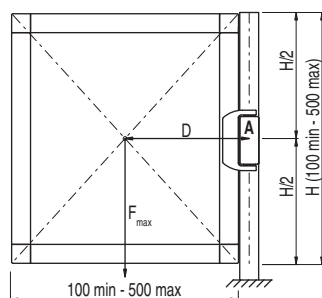

Doors with one safety hinge and one additional hinge
 $F_{max} (N) = 400,000/D$ (mm)

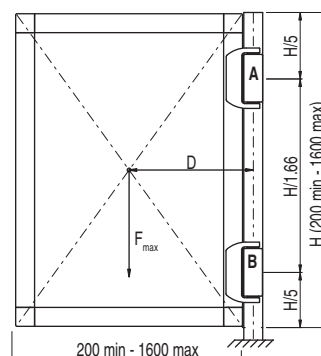

Doors with one safety hinge and two additional hinges
 $F_{max} (N) = 500,000/D$ (mm)

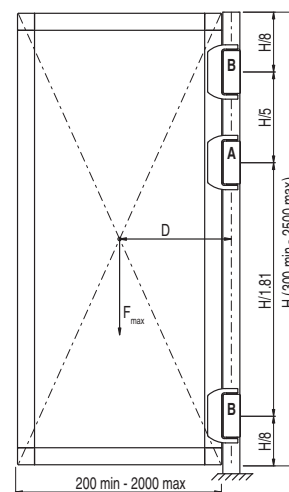

Legend

F_{max}	Force exerted by the weight of the door (N)
D	Distance from the centre of gravity of the door to the axis of the hinge (mm)
A	Safety hinge
B	Additional hinge

