

Description

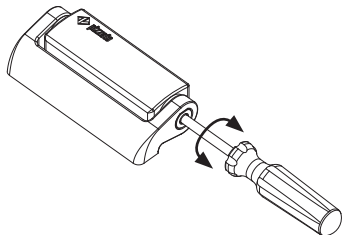

The HP - HC series hinge switches from Pizzato Elettrica combine safety and style in a single product. The electric switch is fully integrated into the mechanical hinge so that it is virtually invisible to an inexperienced eye. This, besides from being an aesthetic advantage, guarantees greater safety as a switch which is difficult to identify is consequently even more difficult to tamper with. The rear mounting without screws in sight and the very precise line mean the switch can be perfectly integrated even with guards of machinery with a very precise design. Complementary hinges with purely mechanical functions are also available to ensure perfect alignment with the rest of the machine.

Adjustment of the switching point



The switching point of the switches can be set with a screwdriver.

Adjusting the switching point allows for any calibration for large size guards. After calibrating the switch, it is always necessary to close the hole using the safety cap supplied.

Basic activation angle variants

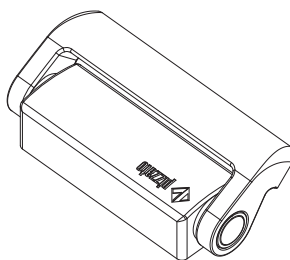

On request, versions with a switch activation angle of 15° multiples (e.g. 45° or 90°) are available.

The different activation angle does not exclude the possibility of adjustment of the switching point by means of the adjustment screw in the switch. Any change in the operating angle clearly does not alter the maximum mechanical switch travel.

Integrated M12 connector

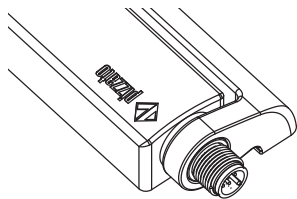

Versions with connection from the top or the bottom are available with integrated M12 connector.

The use of versions with connectors permits faster wiring if guards need to be moved from the test location to the installation site.

Opening angle up to 180°

The mechanical design of the switch also allows use on guards with an opening angle of up to 180°.

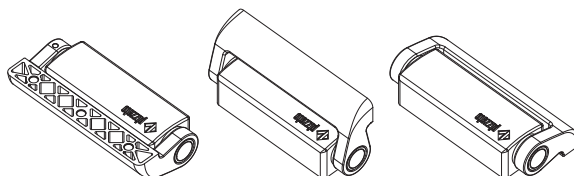

Cable with connector at the back

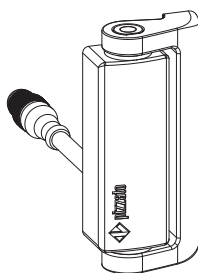

The version with a rear cable and M12 connector is the best combination between aesthetics and connection ease.

If machines need to be assembled at the customer's site, this solution allows the wiring to be hidden. At the same time, it facilitates the connection and disconnection of the wiring from inside the machinery.

Versions for glass or polycarbonate doors

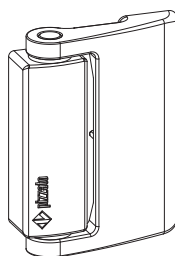

A version of the switch developed exclusively for glass and polycarbonate doors without frame is available.

Installation is facilitated by the larger supporting arm and the spaced fixing points; these also prevent the formation of cracks caused by holes located too close to the edge of the guard.

It is necessary to verify that the switch is not used as a mechanical stop for the door.

Protection degrees IP67 and IP69K

IP69K
IP67

These devices are designed to be used in the toughest environmental conditions and they pass the IP67 immersion test acc. to EN 60529. They can therefore be used in all environments where maximum protection degree of the housing is required. Due to

their special design, these devices are suitable for use in equipment subjected to cleaning with high pressure hot water jets. These devices meet the IP69K test requirements according to ISO 20653 (water jets with 100 bar and 80°C).

Additional hinges

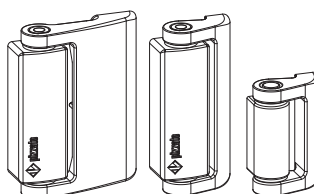

To complete the installation, various types of additional hinges are available to be used in a variable number depending on the weight of the guard.

These hinges have the same aesthetic but cost less as they contain no electrical parts.

Application examples

- Switch without mounting plate.
- Rear fixing.
- Cable output at the back.



- Switch with angular mounting plate for slotted profile.
- Fixing with internal screws.
- Output with M12 connector at the bottom.

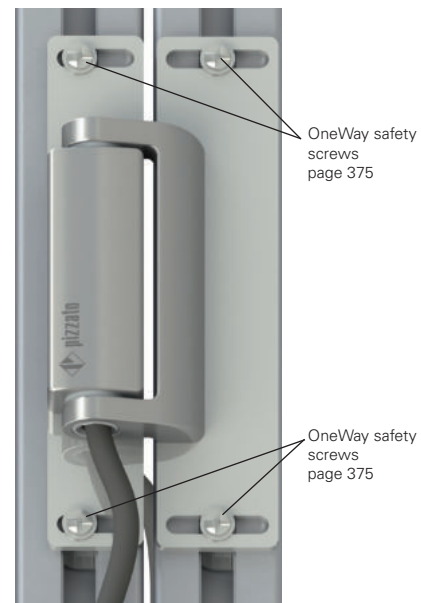

- Switch with straight mounting plate for front slotted profile.
- Fixing with screws at the back.
- Cable output at the bottom.

Closed door



- Direct fixing to the polycarbonate plate.
- Switch without mounting plate.
- Fixing with internal screws.
- Output with connector at the back.

Open door

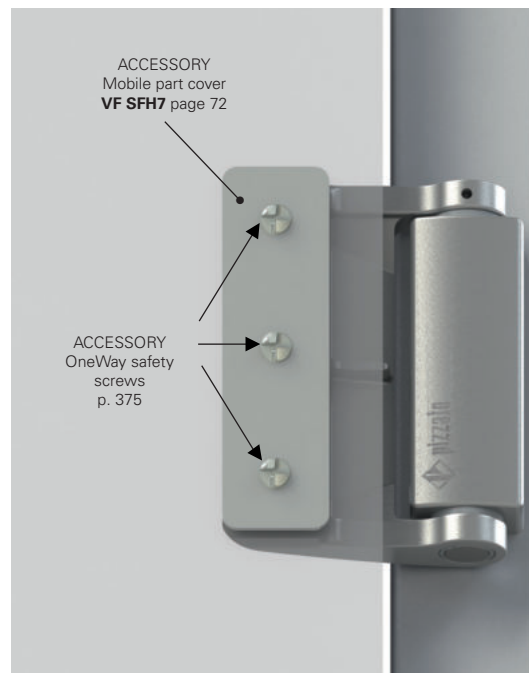

Selection diagram

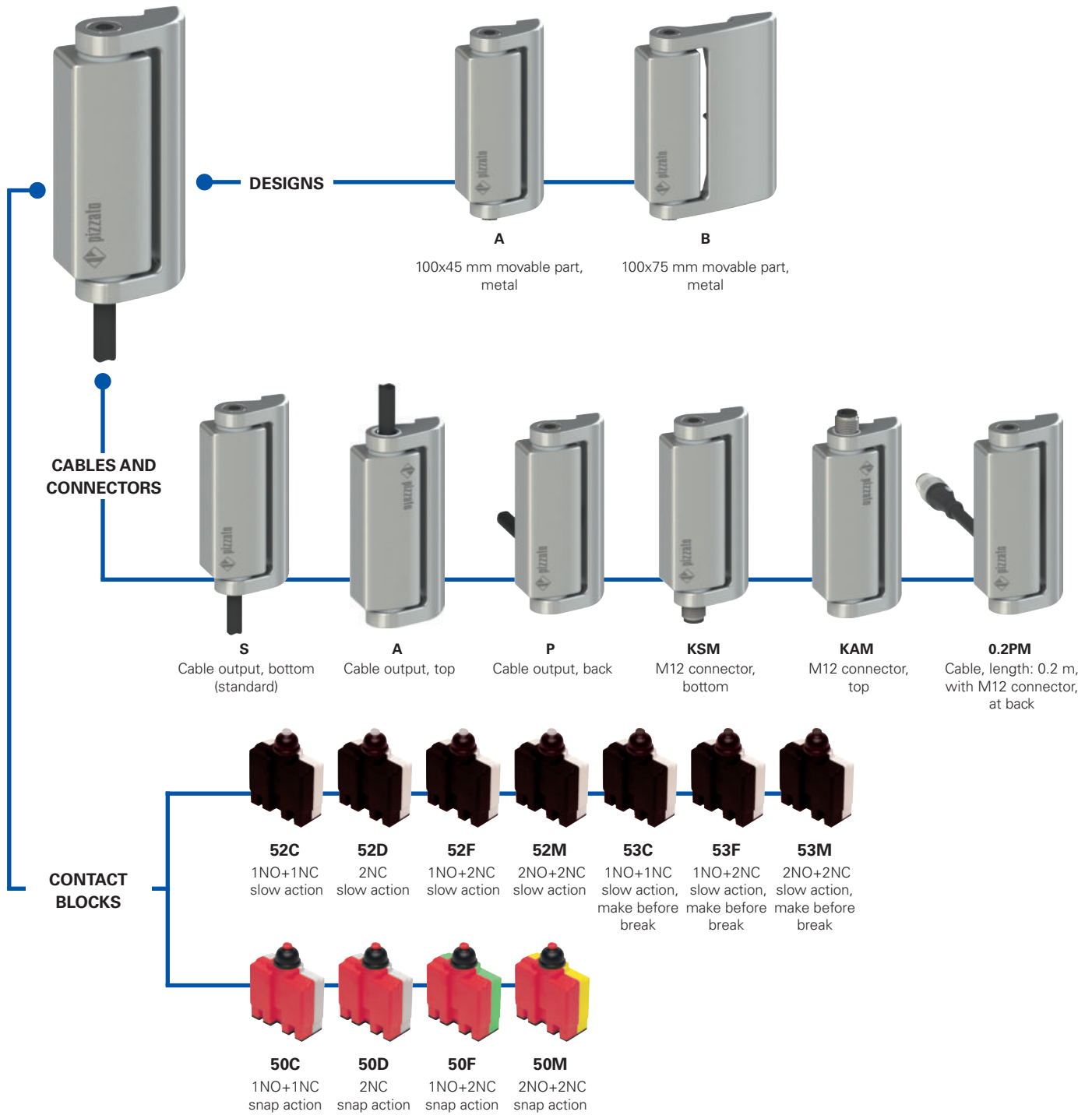

ADDITIONAL HINGES



—●— product option

**Code structure****Attention!** The feasibility of a code number does not mean the effective availability of a product. Please contact our sales office.

article
options

HP AA052C-2SNGH15T6

Movable part	
A	100x45 mm movable part, metal
B	100x75 mm movable part, metal

Ambient temperature	
T6	-40°C ... +80°C

Contact block	
52C	1NO+1NC, slow action
52D	2NC, slow action
52F	1NO+2NC, slow action
52M	2NO+2NC, slow action
53C	1NO+1NC, slow action, make before break
53F	1NO+2NC, slow action, make before break
53M	2NO+2NC, slow action, make before break
50C	1NO+1NC, snap action
50D	2NC, snap action
50F	1NO+2NC, snap action
50M	2NO+2NC, snap action

The versions with snap-action contact blocks are recommended for doors having a radius not greater than 600 mm.

Connection type	
0.2	cable, length: 0.2 m with M12 connector (available for 0.2 PM versions only)
0.5	cable, length: 0.5 m
...
2	cable, length: 2 m (standard)
...
10	cable, length: 10 m
K	integrated M12 connector

Activation angle	
	0° activation angle (standard)
H15	15° activation angle
H30	30° activation angle
H45	45° activation angle
H60	60° activation angle
H75	75° activation angle
H90	90° activation angle
H105	105° activation angle
H120	120° activation angle
H135	135° activation angle
H345	345° activation angle

Contact type	
	silver contacts (standard)
G	silver contacts with 1 µm gold coating

Cable or connector type	
N	PVC cable, IEC 60332-1-2 oil-resistant (standard)
E	PVC cable, IEC 60332-1-2 (with 2 contacts only)
H	PUR cable, halogen free
R	cable for railway applications (EN 50306-4)
M	M12 connector

Output direction, connections	
S	movable part at the right and bottom output
P	movable part at the right and output at the back
A	movable part at the right and output at top
Q	movable part at the left and output at the back

Code structure for additional hinges

article
options

HC AA-V46

Movable part	
HC AA	100x45 mm
HC AB	100x75 mm
HC LL	65x45 mm

Ground connection	
	with no ground connection between the fixed part and the moving part (standard)
V46	with ground connection between the fixed part and the moving part



Main features

- Metal housing, cable output at top, bottom or back
- 4 types of integrated cable available
- Versions with M12 connector
- Protection degrees IP67 and IP69K
- 11 contact blocks with positive opening \oplus
- Additional hinges without contacts

Quality marks:



IMQ approval:	CA02.03746
UL approval:	E131787
CCC approval:	2020970305002291
EAC approval:	RU C-IT.YT03.B.00035/19

Technical data

Housing

Metal housing, powder-coated
 Versions with integrated cable, length 2 m, other lengths from 0.5 ... 10 m on request
 Versions with integrated M12 connector
 Versions with M12 connector and 0.2 m cable, other lengths from 0.1 ... 3 m on request

Protection degree:	IP67 acc. to EN 60529 IP69K acc. to ISO 20653 (Protect the cables from direct high-pressure and high-temperature jets)
Corrosion resistance in saline mist:	≥ 300 hours in NSS acc. to ISO 9227

General data

SIL (SIL CL) up to:	SIL 3 acc. to EN 62061*
Performance Level (PL) up to:	PL e acc. to EN ISO 13849-1*
Mechanical interlock, not coded:	type 1 acc. to EN ISO 14119
Safety parameters:	
B_{100} :	5,000,000 for NC contacts
Mission time	20 years
Ambient temperature for hinges without cable:	-25°C ... +80°C (standard) -40°C ... +80°C (T6 option)
Ambient temperature for hinges with cable:	See table on page 54
Max. actuation frequency:	1200 operating cycles/hour
Mechanical endurance:	1 million operating cycles
Max. actuation speed:	90°/s
Min. actuation speed:	2°/s
Mounting position:	any
Tightening torque, M5 screws:	3 ... 5 Nm

Electrical data

Rated impulse withstand voltage U_{imp} :	4 kV
Conditional short circuit current:	1000 A acc. to EN 60947-5-1
Pollution degree:	3

In compliance with standards:

IEC 60947-5-1, IEC 60947-1, IEC 60204-1, EN ISO 14119, EN ISO 12100, IEC 60529, EN IEC 63000, ISO 20653, UL 508, CSA 22.2 No.14.

Approvals:

EN 60947-5-1, UL 508, CSA 22.2 No.14, GB/T14048.5

Compliance with the requirements of:

Machinery Directive 2006/42/EC, EMC Directive 2014/30/EU, RoHS Directive 2011/65/EU.

Positive contact opening in conformity with standards:

IEC 60947-5-1, EN 60947-5-1.

⚠ If not expressly indicated in this chapter, for correct installation and utilization of all articles see the instructions given on pages 377 to 392.

⚠ Important: Switch off the circuit voltage before disconnecting the connector from the switch. The connector is not suitable for separation of electrical loads. According to EN 60204-1, versions with 8-pole M12 (2NO+2NC) connector can be used only in SELV circuits.

Features approved by IMQ

Rated insulation voltage (U_i):	250 Vac
Conventional free air thermal current (I _{th}):	10 A (1-2 contacts) / 6 A (2-3 contacts) / 4 A (4 contacts or 5-pole M12 connector)
Protection against short circuits (fuse):	10 A (1-2 contacts) / 6 A (2-3 contacts) / 4 A (4 contacts or 5-pole M12 connector) type gG
Rated impulse withstand voltage (U_{imp}):	4 kV
Protection degree of the housing:	IP67
MA terminals (crimped terminals)	
Pollution degree:	3
Utilization category:	AC15 / DC13 (with connector)
Operating voltage (U_o):	250 Vac (50 Hz) / 24 Vdc (with connector)
Operating current (I _o):	3 A / 2 A (with connector)

Forms of the contact element: X, Y, Zb, X+X, Y+Y, Y+Y+X, X+X+Y, X+X+Y+Y
 Positive opening contacts on contact blocks 50A, 50C, 50D, 50F, 50G, 50M, 51A, 51C, 51D, 51F, 51G, 51M, 52A, 52C, 52D, 52F, 52G, 52M, 53A, 53C, 53D, 53F, 53G, 53M

In compliance with standards: EN 60947-1, EN 60947-5-1, fundamental requirements of the Low Voltage Directive 2014/35/EU.

Please contact our technical department for the list of approved products.

Features approved by UL

Electrical Ratings:	R300 pilot duty (28 VA, 125-250 Vdc) B300 pilot duty (360 VA, 120-240 Vac) (1-2-3 cont.) C300 pilot duty (180 VA, 120-240 Vac) (4 cont.) 24 Vac, Class 2, 2 A pilot duty (M12 connector) 24 Vdc, Class 2, 0.22 A pilot duty (M12 connector)
Environmental Ratings:	Type 1

Please contact our technical department for the list of approved products.



Ambient temperatures for hinges with cable and electrical data

Cable features	Connection type		Output with cable						Output with M12 connector	
	Contact blocks		2 contacts		3 contacts		4 contacts		2 contacts	3 or 4 contacts
	E	N	H	R	N	H	N	R	M12 connector, 5-pole	M12 connector, 8-pole
Conductors	5x0.75 mm ²	5x0.75 mm ²	5x0.75 mm ²	5x0.5mm ²	7x0.5 mm ²	7x0.5 mm ²	9x0.34 mm ²	9x0.5 mm ²	5x0.25 mm ²	8x0.25 mm ²
Application field	General	General	General, mobile installation	Rail	General	General, mobile installation	General	Rail	General	General
In compliance with standards	H05VV-F	H05VV5-F	05EQ-H	EN50306-4 IE-300V 9G0.5 mm ² MM-90 EN 50306-4 EN 45545	03VV-F	03E7Q-H	03VV-F	EN50306-4 1P-300V- 9G0.5 mm ² MM-90 EN 50306-4 EN 45545	03VV-H	03VV-H
Sheath	PVC	PVC OIL RESISTANT	PUR HALOGEN FREE	/	PVC OIL RESISTANT	PUR HALOGEN FREE	PVC OIL RESISTANT	/	PVC OIL RESISTANT	PVC OIL RESISTANT
Self-extinguishing	IEC 60332-1-2	IEC 60332-1-2 UL 758:FT1 CEI 20-22 II	IEC 60332-1-2 UL 758:FT1	IEC 60332-1 EN 50305 EN 50306-1	IEC 60332-1-2 UL 758:FT1 CEI 20-22 II	IEC 60332-1-2 UL 758:FT1	IEC 60332-1-2 UL 758:FT1 CEI 20-22 II	IEC 60332-1 EN 50305 EN 50306-1	IEC 60332-1-2 CEI 20-22 II UL 758:FT1	IEC 60332-1-2 CEI 20-22 II UL 758:FT1
Oil resistant	/	UL 758 CSA 22.2 N°210	UL 758 CSA 22.2 N°210	/	UL 758 CSA 22.2 N°210	UL 758	UL 758 CSA 22.2 N°210	/	UL 758 CSA 22.2 N°210	UL 758 CSA 22.2 N°210
Max. speed	/	/	300 m/min	/	/	300 m/min	/	/	50 m/min	50m/min
Max. acceleration	/	/	30 m/s ²	/	/	30 m/s ²	/	/	5 m/s ²	5m/s ²
Minimum bending radius	80 mm	80 mm	80 mm	60 mm	108 mm	80 mm	108 mm	65 mm	75 mm	90 mm
Outer diameter	8 mm	8 mm	8 mm	6 mm	7 mm	7 mm	7 mm	6.5 mm	6 mm	6 mm
End stripped	80 mm	80 mm	80 mm	80 mm	80 mm	80 mm	80 mm	80 mm	/	/
Copper conductors IEC 60228	Class 5	Class 5	Class 6	Class 5	Class 5	Class 6	Class 5	Class 5	Class 6	Class 6
Engraving	Standard	6268	6280	Standard	6274	6282	6278	Standard	6267	6275

Ambient temperature with cable standard extended (T6)	Cable, fixed installation	-15°C +60°C	-25°C +80°C	-25°C +80°C	-25°C +80°C	-25°C +80°C	-25°C +80°C	-25°C +80°C	-25°C +80°C	-25°C +80°C	-25°C +80°C
	Cable, flexible installation	+5°C +60°C	-5°C +80°C	-25°C +80°C	-25°C +80°C	-5°C +80°C	-25°C +80°C	-5°C +80°C	-25°C +80°C	-15°C +80°C	-15°C +80°C
	Cable, mobile installation	/	/	-25°C +80°C	/	/	-25°C +80°C	/	/	-15°C +80°C	-15°C +80°C
	Cable, fixed installation	/	/	-40°C +80°C	-40°C +80°C	/	-40°C +80°C	/	-40°C +80°C	/	/
	Cable, flexible installation	/	/	-40°C +80°C	-40°C +80°C	/	-40°C +80°C	/	-40°C +80°C	/	/
	Cable, mobile installation	/	/	-40°C +80°C	/	/	-40°C +80°C	/	/	/	/

Electrical data	Thermal current I _{th}	10 A	10 A	10 A	6 A	6 A	6 A	3 A	4 A	4 A	2 A	
	Rated insulation voltage U _i	250 Vac	250 Vac	250 Vac	250 Vac	250 Vac	250 Vac	250 Vac	250 Vac	250 Vac	300 Vdc	36 Vdc
	Protection against short circuits (fuse)	10 A 500 V type gG	10 A 500 V type gG	10 A 500 V type gG	6 A 500 V type gG	6 A 500 V type gG	6 A 500 V type gG	3 A 500 V type gG	4 A 500 V type gG	4 A 500 V type gG	4 A 500 V type gG	2 A 500V type gG
	Utilization category DC13	24 V	2 A	2 A	2 A	2 A	2 A	2 A	2 A	2 A	2 A	2 A
		125 V	0.4 A	0.4 A	0.4 A	0.4 A	0.4 A	0.4 A	0.4 A	0.4 A	0.4 A	/
		250 V	0.3 A	0.3 A	0.3 A	0.3 A	0.3 A	0.3 A	0.3 A	0.3 A	0.3 A	/
	Utilization category AC15	24 V	4 A	4 A	4 A	4 A	4 A	4 A	3 A	4 A	4 A	2 A
120 V		4 A	4 A	4 A	4 A	4 A	4 A	3 A	4 A	4 A	/	
250 V		4 A	4 A	4 A	4 A	4 A	4 A	3 A	4 A	4 A	/	
Approvals	CE cULus IMQ EAC CCC	CE cULus IMQ EAC CCC	CE cULus IMQ EAC CCC	CE IMQ EAC CCC	CE cULus IMQ EAC CCC	CE cULus IMQ EAC CCC	CE cULus IMQ EAC CCC	CE cULus IMQ EAC CCC	CE IMQ EAC CCC	CE cULus IMQ EAC CCC	CE cULus EAC	

Internal cable wiring

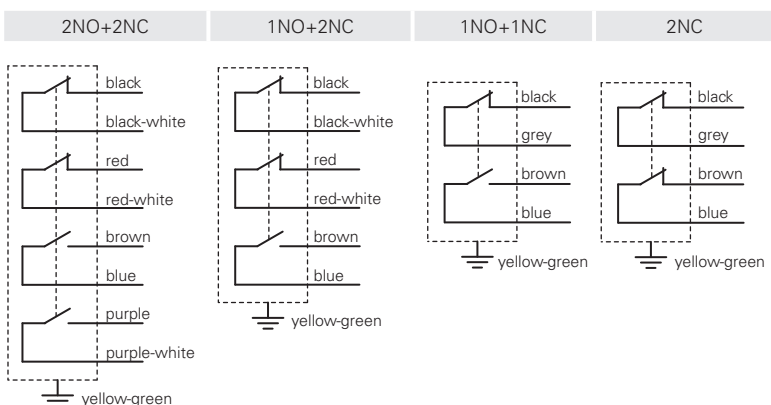

Connector pin assignment

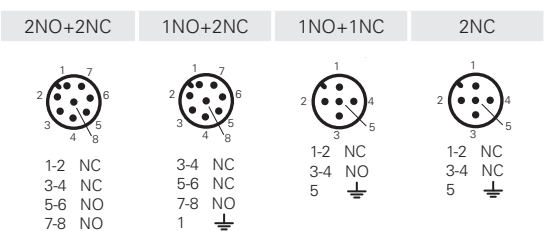

Female connectors See page 359

		2 m cable, bottom	2 m cable, top	2 m cable, back																																																																																																			
Contact type																																																																																																							
Contact block		<table border="1"> <tr> <td>52C</td> <td>L</td> <td>HP AA052C-2SN</td> <td>→</td> <td>1NO+1NC</td> <td>HP AA052C-2AN</td> <td>→</td> <td>1NO+1NC</td> <td>HP AA052C-2PN</td> <td>→</td> <td>1NO+1NC</td> </tr> <tr> <td>52D</td> <td>L</td> <td>HP AA052D-2SN</td> <td>→</td> <td>2NC</td> <td>HP AA052D-2AN</td> <td>→</td> <td>2NC</td> <td>HP AA052D-2PN</td> <td>→</td> <td>2NC</td> </tr> <tr> <td>52F</td> <td>L</td> <td>HP AA052F-2SN</td> <td>→</td> <td>1NO+2NC</td> <td>HP AA052F-2AN</td> <td>→</td> <td>1NO+2NC</td> <td>HP AA052F-2PN</td> <td>→</td> <td>1NO+2NC</td> </tr> <tr> <td>52M</td> <td>L</td> <td>HP AA052M-2SN</td> <td>→</td> <td>2NO+2NC</td> <td>HP AA052M-2AN</td> <td>→</td> <td>2NO+2NC</td> <td>HP AA052M-2PN</td> <td>→</td> <td>2NO+2NC</td> </tr> <tr> <td>53C</td> <td>LO</td> <td>HP AA053C-2SN</td> <td>→</td> <td>1NO+1NC</td> <td>HP AA053C-2AN</td> <td>→</td> <td>1NO+1NC</td> <td>HP AA053C-2PN</td> <td>→</td> <td>1NO+1NC</td> </tr> <tr> <td>53F</td> <td>LO</td> <td>HP AA053F-2SN</td> <td>→</td> <td>1NO+2NC</td> <td>HP AA053F-2AN</td> <td>→</td> <td>1NO+2NC</td> <td>HP AA053F-2PN</td> <td>→</td> <td>1NO+2NC</td> </tr> <tr> <td>53M</td> <td>LO</td> <td>HP AA053M-2SN</td> <td>→</td> <td>2NO+2NC</td> <td>HP AA053M-2AN</td> <td>→</td> <td>2NO+2NC</td> <td>HP AA053M-2PN</td> <td>→</td> <td>2NO+2NC</td> </tr> <tr> <td>Actuating force</td> <td></td> <td colspan="3">0.3 Nm (0.65 Nm →)</td> <td colspan="3">0.3 Nm (0.65 Nm →)</td> <td colspan="3">0.3 Nm (0.65 Nm →)</td> </tr> <tr> <td>Travel diagrams</td> <td></td> <td colspan="3">page 72 - group 1</td> <td colspan="3">page 72 - group 1</td> <td colspan="3">page 72 - group 1</td> </tr> </table>			52C	L	HP AA052C-2SN	→	1NO+1NC	HP AA052C-2AN	→	1NO+1NC	HP AA052C-2PN	→	1NO+1NC	52D	L	HP AA052D-2SN	→	2NC	HP AA052D-2AN	→	2NC	HP AA052D-2PN	→	2NC	52F	L	HP AA052F-2SN	→	1NO+2NC	HP AA052F-2AN	→	1NO+2NC	HP AA052F-2PN	→	1NO+2NC	52M	L	HP AA052M-2SN	→	2NO+2NC	HP AA052M-2AN	→	2NO+2NC	HP AA052M-2PN	→	2NO+2NC	53C	LO	HP AA053C-2SN	→	1NO+1NC	HP AA053C-2AN	→	1NO+1NC	HP AA053C-2PN	→	1NO+1NC	53F	LO	HP AA053F-2SN	→	1NO+2NC	HP AA053F-2AN	→	1NO+2NC	HP AA053F-2PN	→	1NO+2NC	53M	LO	HP AA053M-2SN	→	2NO+2NC	HP AA053M-2AN	→	2NO+2NC	HP AA053M-2PN	→	2NO+2NC	Actuating force		0.3 Nm (0.65 Nm →)			0.3 Nm (0.65 Nm →)			0.3 Nm (0.65 Nm →)			Travel diagrams		page 72 - group 1			page 72 - group 1			page 72 - group 1		
52C	L	HP AA052C-2SN	→	1NO+1NC	HP AA052C-2AN	→	1NO+1NC	HP AA052C-2PN	→	1NO+1NC																																																																																													
52D	L	HP AA052D-2SN	→	2NC	HP AA052D-2AN	→	2NC	HP AA052D-2PN	→	2NC																																																																																													
52F	L	HP AA052F-2SN	→	1NO+2NC	HP AA052F-2AN	→	1NO+2NC	HP AA052F-2PN	→	1NO+2NC																																																																																													
52M	L	HP AA052M-2SN	→	2NO+2NC	HP AA052M-2AN	→	2NO+2NC	HP AA052M-2PN	→	2NO+2NC																																																																																													
53C	LO	HP AA053C-2SN	→	1NO+1NC	HP AA053C-2AN	→	1NO+1NC	HP AA053C-2PN	→	1NO+1NC																																																																																													
53F	LO	HP AA053F-2SN	→	1NO+2NC	HP AA053F-2AN	→	1NO+2NC	HP AA053F-2PN	→	1NO+2NC																																																																																													
53M	LO	HP AA053M-2SN	→	2NO+2NC	HP AA053M-2AN	→	2NO+2NC	HP AA053M-2PN	→	2NO+2NC																																																																																													
Actuating force		0.3 Nm (0.65 Nm →)			0.3 Nm (0.65 Nm →)			0.3 Nm (0.65 Nm →)																																																																																															
Travel diagrams		page 72 - group 1			page 72 - group 1			page 72 - group 1																																																																																															

		M12 connector, bottom	M12 connector, top	cable (0.2 m) with M12 connector, back																																																																																																			
Contact type																																																																																																							
Contact block		<table border="1"> <tr> <td>52C</td> <td>L</td> <td>HP AA052C-KSM</td> <td>→</td> <td>1NO+1NC</td> <td>HP AA052C-KAM</td> <td>→</td> <td>1NO+1NC</td> <td>HP AA052C-0.2PM</td> <td>→</td> <td>1NO+1NC</td> </tr> <tr> <td>52D</td> <td>L</td> <td>HP AA052D-KSM</td> <td>→</td> <td>2NC</td> <td>HP AA052D-KAM</td> <td>→</td> <td>2NC</td> <td>HP AA052D-0.2PM</td> <td>→</td> <td>2NC</td> </tr> <tr> <td>52F</td> <td>L</td> <td>HP AA052F-KSM</td> <td>→</td> <td>1NO+2NC</td> <td>HP AA052F-KAM</td> <td>→</td> <td>1NO+2NC</td> <td>HP AA052F-0.2PM</td> <td>→</td> <td>1NO+2NC</td> </tr> <tr> <td>52M</td> <td>L</td> <td>HP AA052M-KSM</td> <td>→</td> <td>2NO+2NC</td> <td>HP AA052M-KAM</td> <td>→</td> <td>2NO+2NC</td> <td>HP AA052M-0.2PM</td> <td>→</td> <td>2NO+2NC</td> </tr> <tr> <td>53C</td> <td>LO</td> <td>HP AA053C-KSM</td> <td>→</td> <td>1NO+1NC</td> <td>HP AA053C-KAM</td> <td>→</td> <td>1NO+1NC</td> <td>HP AA053C-0.2PM</td> <td>→</td> <td>1NO+1NC</td> </tr> <tr> <td>53F</td> <td>LO</td> <td>HP AA053F-KSM</td> <td>→</td> <td>1NO+2NC</td> <td>HP AA053F-KAM</td> <td>→</td> <td>1NO+2NC</td> <td>HP AA053F-0.2PM</td> <td>→</td> <td>1NO+2NC</td> </tr> <tr> <td>53M</td> <td>LO</td> <td>HP AA053M-KSM</td> <td>→</td> <td>2NO+2NC</td> <td>HP AA053M-KAM</td> <td>→</td> <td>2NO+2NC</td> <td>HP AA053M-0.2PM</td> <td>→</td> <td>2NO+2NC</td> </tr> <tr> <td>Actuating force</td> <td></td> <td colspan="3">0.3 Nm (0.65 Nm →)</td> <td colspan="3">0.3 Nm (0.65 Nm →)</td> <td colspan="3">0.3 Nm (0.65 Nm →)</td> </tr> <tr> <td>Travel diagrams</td> <td></td> <td colspan="3">page 72 - group 1</td> <td colspan="3">page 72 - group 1</td> <td colspan="3">page 72 - group 1</td> </tr> </table>			52C	L	HP AA052C-KSM	→	1NO+1NC	HP AA052C-KAM	→	1NO+1NC	HP AA052C-0.2PM	→	1NO+1NC	52D	L	HP AA052D-KSM	→	2NC	HP AA052D-KAM	→	2NC	HP AA052D-0.2PM	→	2NC	52F	L	HP AA052F-KSM	→	1NO+2NC	HP AA052F-KAM	→	1NO+2NC	HP AA052F-0.2PM	→	1NO+2NC	52M	L	HP AA052M-KSM	→	2NO+2NC	HP AA052M-KAM	→	2NO+2NC	HP AA052M-0.2PM	→	2NO+2NC	53C	LO	HP AA053C-KSM	→	1NO+1NC	HP AA053C-KAM	→	1NO+1NC	HP AA053C-0.2PM	→	1NO+1NC	53F	LO	HP AA053F-KSM	→	1NO+2NC	HP AA053F-KAM	→	1NO+2NC	HP AA053F-0.2PM	→	1NO+2NC	53M	LO	HP AA053M-KSM	→	2NO+2NC	HP AA053M-KAM	→	2NO+2NC	HP AA053M-0.2PM	→	2NO+2NC	Actuating force		0.3 Nm (0.65 Nm →)			0.3 Nm (0.65 Nm →)			0.3 Nm (0.65 Nm →)			Travel diagrams		page 72 - group 1			page 72 - group 1			page 72 - group 1		
52C	L	HP AA052C-KSM	→	1NO+1NC	HP AA052C-KAM	→	1NO+1NC	HP AA052C-0.2PM	→	1NO+1NC																																																																																													
52D	L	HP AA052D-KSM	→	2NC	HP AA052D-KAM	→	2NC	HP AA052D-0.2PM	→	2NC																																																																																													
52F	L	HP AA052F-KSM	→	1NO+2NC	HP AA052F-KAM	→	1NO+2NC	HP AA052F-0.2PM	→	1NO+2NC																																																																																													
52M	L	HP AA052M-KSM	→	2NO+2NC	HP AA052M-KAM	→	2NO+2NC	HP AA052M-0.2PM	→	2NO+2NC																																																																																													
53C	LO	HP AA053C-KSM	→	1NO+1NC	HP AA053C-KAM	→	1NO+1NC	HP AA053C-0.2PM	→	1NO+1NC																																																																																													
53F	LO	HP AA053F-KSM	→	1NO+2NC	HP AA053F-KAM	→	1NO+2NC	HP AA053F-0.2PM	→	1NO+2NC																																																																																													
53M	LO	HP AA053M-KSM	→	2NO+2NC	HP AA053M-KAM	→	2NO+2NC	HP AA053M-0.2PM	→	2NO+2NC																																																																																													
Actuating force		0.3 Nm (0.65 Nm →)			0.3 Nm (0.65 Nm →)			0.3 Nm (0.65 Nm →)																																																																																															
Travel diagrams		page 72 - group 1			page 72 - group 1			page 72 - group 1																																																																																															

Attention! The safety hinge switch can be combined together exclusively with one or more Pizzato Elettrica hinges (HP or HC series). The use of whichever other hinge does not guarantee the correct operation of the safety device.



		2 m cable, bottom	2 m cable, top	2 m cable, back																																																																																																			
Contact type L = slow action LO = slow action, make before break																																																																																																							
Contact block		<table border="1"> <tr> <td>52C</td> <td>L</td> <td>HP AB052C-2SN</td> <td>⊕</td> <td>1NO+1NC</td> <td>HP AB052C-2AN</td> <td>⊕</td> <td>1NO+1NC</td> <td>HP AB052C-2PN</td> <td>⊕</td> <td>1NO+1NC</td> </tr> <tr> <td>52D</td> <td>L</td> <td>HP AB052D-2SN</td> <td>⊕</td> <td>2NC</td> <td>HP AB052D-2AN</td> <td>⊕</td> <td>2NC</td> <td>HP AB052D-2PN</td> <td>⊕</td> <td>2NC</td> </tr> <tr> <td>52F</td> <td>L</td> <td>HP AB052F-2SN</td> <td>⊕</td> <td>1NO+2NC</td> <td>HP AB052F-2AN</td> <td>⊕</td> <td>1NO+2NC</td> <td>HP AB052F-2PN</td> <td>⊕</td> <td>1NO+2NC</td> </tr> <tr> <td>52M</td> <td>L</td> <td>HP AB052M-2SN</td> <td>⊕</td> <td>2NO+2NC</td> <td>HP AB052M-2AN</td> <td>⊕</td> <td>2NO+2NC</td> <td>HP AB052M-2PN</td> <td>⊕</td> <td>2NO+2NC</td> </tr> <tr> <td>53C</td> <td>LO</td> <td>HP AB053C-2SN</td> <td>⊕</td> <td>1NO+1NC</td> <td>HP AB053C-2AN</td> <td>⊕</td> <td>1NO+1NC</td> <td>HP AB053C-2PN</td> <td>⊕</td> <td>1NO+1NC</td> </tr> <tr> <td>53F</td> <td>LO</td> <td>HP AB053F-2SN</td> <td>⊕</td> <td>1NO+2NC</td> <td>HP AB053F-2AN</td> <td>⊕</td> <td>1NO+2NC</td> <td>HP AB053F-2PN</td> <td>⊕</td> <td>1NO+2NC</td> </tr> <tr> <td>53M</td> <td>LO</td> <td>HP AB053M-2SN</td> <td>⊕</td> <td>2NO+2NC</td> <td>HP AB053M-2AN</td> <td>⊕</td> <td>2NO+2NC</td> <td>HP AB053M-2PN</td> <td>⊕</td> <td>2NO+2NC</td> </tr> <tr> <td>Actuating force</td> <td colspan="2">0.3 Nm (0.65 Nm ⊕)</td> <td colspan="2">0.3 Nm (0.65 Nm ⊕)</td> <td colspan="2">0.3 Nm (0.65 Nm ⊕)</td> <td colspan="2">0.3 Nm (0.65 Nm ⊕)</td> <td colspan="2">0.3 Nm (0.65 Nm ⊕)</td> </tr> <tr> <td>Travel diagrams</td> <td colspan="2">page 72 - group 1</td> <td colspan="2">page 72 - group 1</td> <td colspan="2">page 72 - group 1</td> <td colspan="2">page 72 - group 1</td> <td colspan="2">page 72 - group 1</td> </tr> </table>			52C	L	HP AB052C-2SN	⊕	1NO+1NC	HP AB052C-2AN	⊕	1NO+1NC	HP AB052C-2PN	⊕	1NO+1NC	52D	L	HP AB052D-2SN	⊕	2NC	HP AB052D-2AN	⊕	2NC	HP AB052D-2PN	⊕	2NC	52F	L	HP AB052F-2SN	⊕	1NO+2NC	HP AB052F-2AN	⊕	1NO+2NC	HP AB052F-2PN	⊕	1NO+2NC	52M	L	HP AB052M-2SN	⊕	2NO+2NC	HP AB052M-2AN	⊕	2NO+2NC	HP AB052M-2PN	⊕	2NO+2NC	53C	LO	HP AB053C-2SN	⊕	1NO+1NC	HP AB053C-2AN	⊕	1NO+1NC	HP AB053C-2PN	⊕	1NO+1NC	53F	LO	HP AB053F-2SN	⊕	1NO+2NC	HP AB053F-2AN	⊕	1NO+2NC	HP AB053F-2PN	⊕	1NO+2NC	53M	LO	HP AB053M-2SN	⊕	2NO+2NC	HP AB053M-2AN	⊕	2NO+2NC	HP AB053M-2PN	⊕	2NO+2NC	Actuating force	0.3 Nm (0.65 Nm ⊕)		0.3 Nm (0.65 Nm ⊕)		0.3 Nm (0.65 Nm ⊕)		0.3 Nm (0.65 Nm ⊕)		0.3 Nm (0.65 Nm ⊕)		Travel diagrams	page 72 - group 1		page 72 - group 1		page 72 - group 1		page 72 - group 1		page 72 - group 1	
52C	L	HP AB052C-2SN	⊕	1NO+1NC	HP AB052C-2AN	⊕	1NO+1NC	HP AB052C-2PN	⊕	1NO+1NC																																																																																													
52D	L	HP AB052D-2SN	⊕	2NC	HP AB052D-2AN	⊕	2NC	HP AB052D-2PN	⊕	2NC																																																																																													
52F	L	HP AB052F-2SN	⊕	1NO+2NC	HP AB052F-2AN	⊕	1NO+2NC	HP AB052F-2PN	⊕	1NO+2NC																																																																																													
52M	L	HP AB052M-2SN	⊕	2NO+2NC	HP AB052M-2AN	⊕	2NO+2NC	HP AB052M-2PN	⊕	2NO+2NC																																																																																													
53C	LO	HP AB053C-2SN	⊕	1NO+1NC	HP AB053C-2AN	⊕	1NO+1NC	HP AB053C-2PN	⊕	1NO+1NC																																																																																													
53F	LO	HP AB053F-2SN	⊕	1NO+2NC	HP AB053F-2AN	⊕	1NO+2NC	HP AB053F-2PN	⊕	1NO+2NC																																																																																													
53M	LO	HP AB053M-2SN	⊕	2NO+2NC	HP AB053M-2AN	⊕	2NO+2NC	HP AB053M-2PN	⊕	2NO+2NC																																																																																													
Actuating force	0.3 Nm (0.65 Nm ⊕)		0.3 Nm (0.65 Nm ⊕)		0.3 Nm (0.65 Nm ⊕)		0.3 Nm (0.65 Nm ⊕)		0.3 Nm (0.65 Nm ⊕)																																																																																														
Travel diagrams	page 72 - group 1		page 72 - group 1		page 72 - group 1		page 72 - group 1		page 72 - group 1																																																																																														

		M12 connector, bottom	M12 connector, top	cable (0.2 m) with M12 connector, back																																																																																																			
Contact type L = slow action LO = slow action, make before break																																																																																																							
Contact blocks		<table border="1"> <tr> <td>52C</td> <td>L</td> <td>HP AB052C-KSM</td> <td>⊕</td> <td>1NO+1NC</td> <td>HP AB052C-KAM</td> <td>⊕</td> <td>1NO+1NC</td> <td>HP AB052C-0.2PM</td> <td>⊕</td> <td>1NO+1NC</td> </tr> <tr> <td>52D</td> <td>L</td> <td>HP AB052D-KSM</td> <td>⊕</td> <td>2NC</td> <td>HP AB052D-KAM</td> <td>⊕</td> <td>2NC</td> <td>HP AB052D-0.2PM</td> <td>⊕</td> <td>2NC</td> </tr> <tr> <td>52F</td> <td>L</td> <td>HP AB052F-KSM</td> <td>⊕</td> <td>1NO+2NC</td> <td>HP AB052F-KAM</td> <td>⊕</td> <td>1NO+2NC</td> <td>HP AB052F-0.2PM</td> <td>⊕</td> <td>1NO+2NC</td> </tr> <tr> <td>52M</td> <td>L</td> <td>HP AB052M-KSM</td> <td>⊕</td> <td>2NO+2NC</td> <td>HP AB052M-KAM</td> <td>⊕</td> <td>2NO+2NC</td> <td>HP AB052M-0.2PM</td> <td>⊕</td> <td>2NO+2NC</td> </tr> <tr> <td>53C</td> <td>LO</td> <td>HP AB053C-KSM</td> <td>⊕</td> <td>1NO+1NC</td> <td>HP AB053C-KAM</td> <td>⊕</td> <td>1NO+1NC</td> <td>HP AB053C-0.2PM</td> <td>⊕</td> <td>1NO+1NC</td> </tr> <tr> <td>53F</td> <td>LO</td> <td>HP AB053F-KSM</td> <td>⊕</td> <td>1NO+2NC</td> <td>HP AB053F-KAM</td> <td>⊕</td> <td>1NO+2NC</td> <td>HP AB053F-0.2PM</td> <td>⊕</td> <td>1NO+2NC</td> </tr> <tr> <td>53M</td> <td>LO</td> <td>HP AB053M-KSM</td> <td>⊕</td> <td>2NO+2NC</td> <td>HP AB053M-KAM</td> <td>⊕</td> <td>2NO+2NC</td> <td>HP AB053M-0.2PM</td> <td>⊕</td> <td>2NO+2NC</td> </tr> <tr> <td>Actuating force</td> <td colspan="2">0.3 Nm (0.65 Nm ⊕)</td> <td colspan="2">0.3 Nm (0.65 Nm ⊕)</td> <td colspan="2">0.3 Nm (0.65 Nm ⊕)</td> <td colspan="2">0.3 Nm (0.65 Nm ⊕)</td> <td colspan="2">0.3 Nm (0.65 Nm ⊕)</td> </tr> <tr> <td>Travel diagrams</td> <td colspan="2">page 72 - group 1</td> <td colspan="2">page 72 - group 1</td> <td colspan="2">page 72 - group 1</td> <td colspan="2">page 72 - group 1</td> <td colspan="2">page 72 - group 1</td> </tr> </table>			52C	L	HP AB052C-KSM	⊕	1NO+1NC	HP AB052C-KAM	⊕	1NO+1NC	HP AB052C-0.2PM	⊕	1NO+1NC	52D	L	HP AB052D-KSM	⊕	2NC	HP AB052D-KAM	⊕	2NC	HP AB052D-0.2PM	⊕	2NC	52F	L	HP AB052F-KSM	⊕	1NO+2NC	HP AB052F-KAM	⊕	1NO+2NC	HP AB052F-0.2PM	⊕	1NO+2NC	52M	L	HP AB052M-KSM	⊕	2NO+2NC	HP AB052M-KAM	⊕	2NO+2NC	HP AB052M-0.2PM	⊕	2NO+2NC	53C	LO	HP AB053C-KSM	⊕	1NO+1NC	HP AB053C-KAM	⊕	1NO+1NC	HP AB053C-0.2PM	⊕	1NO+1NC	53F	LO	HP AB053F-KSM	⊕	1NO+2NC	HP AB053F-KAM	⊕	1NO+2NC	HP AB053F-0.2PM	⊕	1NO+2NC	53M	LO	HP AB053M-KSM	⊕	2NO+2NC	HP AB053M-KAM	⊕	2NO+2NC	HP AB053M-0.2PM	⊕	2NO+2NC	Actuating force	0.3 Nm (0.65 Nm ⊕)		0.3 Nm (0.65 Nm ⊕)		0.3 Nm (0.65 Nm ⊕)		0.3 Nm (0.65 Nm ⊕)		0.3 Nm (0.65 Nm ⊕)		Travel diagrams	page 72 - group 1		page 72 - group 1		page 72 - group 1		page 72 - group 1		page 72 - group 1	
52C	L	HP AB052C-KSM	⊕	1NO+1NC	HP AB052C-KAM	⊕	1NO+1NC	HP AB052C-0.2PM	⊕	1NO+1NC																																																																																													
52D	L	HP AB052D-KSM	⊕	2NC	HP AB052D-KAM	⊕	2NC	HP AB052D-0.2PM	⊕	2NC																																																																																													
52F	L	HP AB052F-KSM	⊕	1NO+2NC	HP AB052F-KAM	⊕	1NO+2NC	HP AB052F-0.2PM	⊕	1NO+2NC																																																																																													
52M	L	HP AB052M-KSM	⊕	2NO+2NC	HP AB052M-KAM	⊕	2NO+2NC	HP AB052M-0.2PM	⊕	2NO+2NC																																																																																													
53C	LO	HP AB053C-KSM	⊕	1NO+1NC	HP AB053C-KAM	⊕	1NO+1NC	HP AB053C-0.2PM	⊕	1NO+1NC																																																																																													
53F	LO	HP AB053F-KSM	⊕	1NO+2NC	HP AB053F-KAM	⊕	1NO+2NC	HP AB053F-0.2PM	⊕	1NO+2NC																																																																																													
53M	LO	HP AB053M-KSM	⊕	2NO+2NC	HP AB053M-KAM	⊕	2NO+2NC	HP AB053M-0.2PM	⊕	2NO+2NC																																																																																													
Actuating force	0.3 Nm (0.65 Nm ⊕)		0.3 Nm (0.65 Nm ⊕)		0.3 Nm (0.65 Nm ⊕)		0.3 Nm (0.65 Nm ⊕)		0.3 Nm (0.65 Nm ⊕)																																																																																														
Travel diagrams	page 72 - group 1		page 72 - group 1		page 72 - group 1		page 72 - group 1		page 72 - group 1																																																																																														

Attention! The safety hinge switch can be combined together exclusively with one or more Pizzato Elettrica hinges (HP or HC series). The use of whichever other hinge does not guarantee the correct operation of the safety device.

Additional hinges

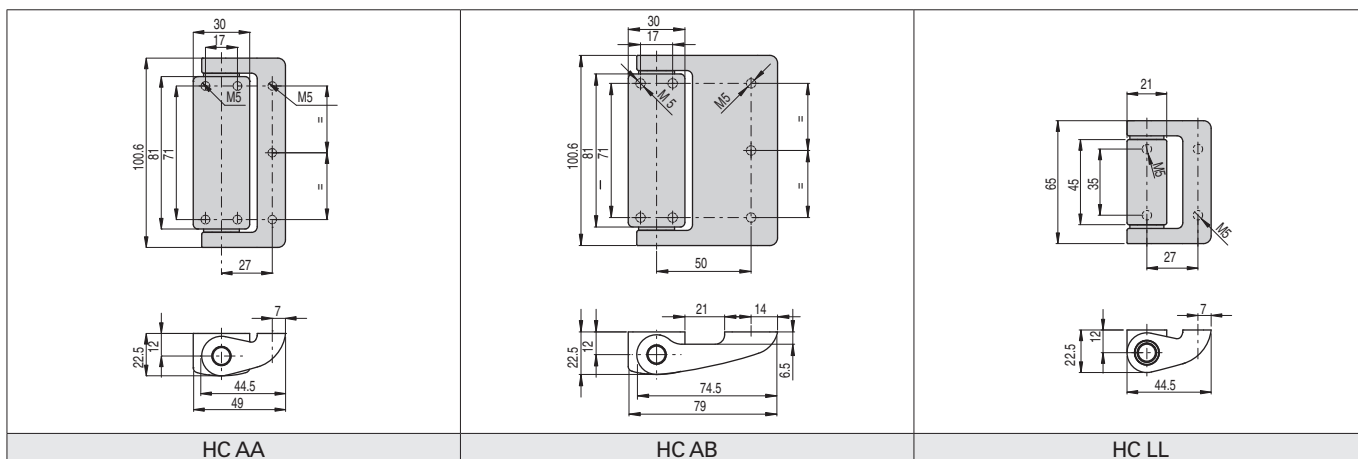

Maximum forces and loads HP AA•••••, HC AA, HC LL

Admitted max. loads, independent of utilization conditions.

Doors with one safety hinge
 $F_{max}(N)=25,000/D$ (mm)

Doors with one safety hinge and one additional hinge
 $F_{max}(N)=200,000/D$ (mm)

Doors with one safety hinge and two additional hinges
 $F_{max}(N)=250,000/D$ (mm)

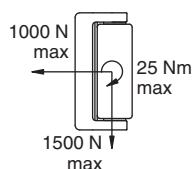

Attention: Never exceed the loads listed above under any circumstances.

The loads have been verified by a fatigue test of one million operating cycles with a 90° opening angle.

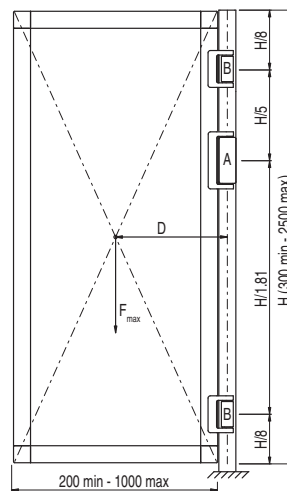
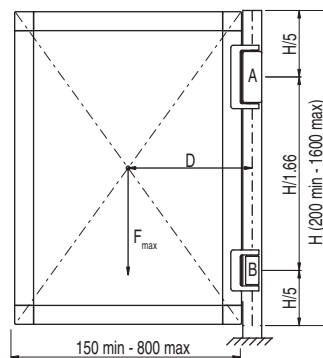
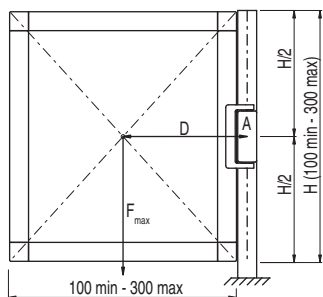

Legend

- F_{max} Force exerted by the weight of the door (N)
- D Distance from the centre of gravity of the door to the axis of the hinge (mm)
- A Safety hinge
- B Additional hinge

Maximum forces and loads HP AB•••••, HC AB

Admitted max. loads, independent of utilization conditions.

Doors with one safety hinge
 $F_{max}(N)=12,500/D$ (mm)

Doors with one safety hinge and one additional hinge
 $F_{max}(N)=100,000/D$ (mm)

Doors with one safety hinge and two additional hinges
 $F_{max}(N)=200,000/D$ (mm)

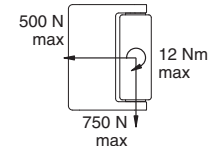

Attention: Never exceed the loads listed above under any circumstances.

The loads have been verified by a fatigue test of one million operating cycles with a 90° opening angle.

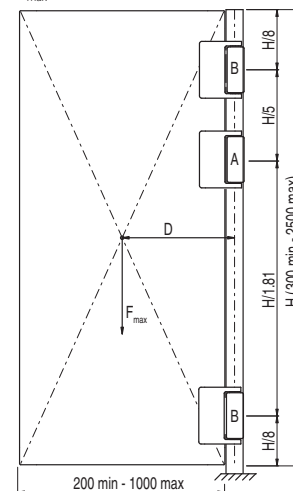
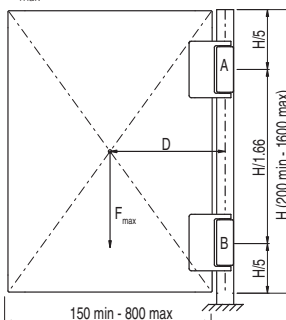
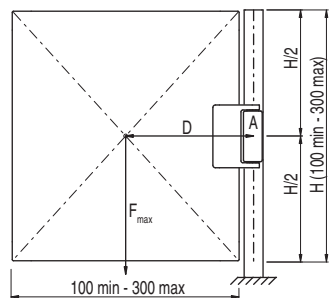

Legend

- F_{max} Force exerted by the weight of the door (N)
- D Distance from the centre of gravity of the door to the axis of the hinge (mm)
- A Safety hinge
- B Additional hinge

Accessories

Article	Description
VF AC7032	Protection cap for adjustment screw



The cap is supplied with every hinge and must always be inserted after the adjustment of the switching point.
In case of loss or damage, the cap can be ordered separately.

All values in the drawings are in mm

Accessories See page 359

→ The 2D and 3D files are available at www.pizzato.com



Travel diagrams

Contact block	Group 1	Contact block	Group 1	Contact block	Group 1
52C 1NO+1NC		53C 1NO+1NC		50C 1NO+1NC	
52D 2NC		53F 1NO+2NC		50D 2NC	
52F 1NO+2NC		53M 2NO+2NC		50F 1NO+2NC	
52M 2NO+2NC				50M 2NO+2NC	

Legend

- Closed contact
- Open contact
- Positive opening travel
- Switch pressed / Switch released

The switching point of the contacts can be adjusted from 0° to +4° compared to that indicated in the travel diagrams. The hinge is supplied without pre-adjustment.

Fixing plates

Fastening screws for profile not supplied.

Article	Description	Article	Description
VF SFH1-C	Couple of angular plates for HP AA and HC AA supplied with fastening screws for attachment of the switch	VF SFH2-C	Couple of angular plates for HC LL supplied with fastening screws for attachment of the switch

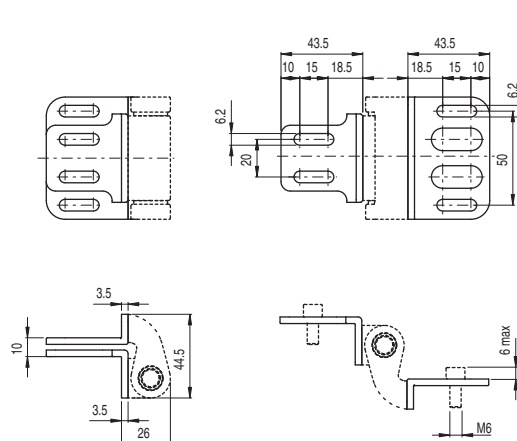
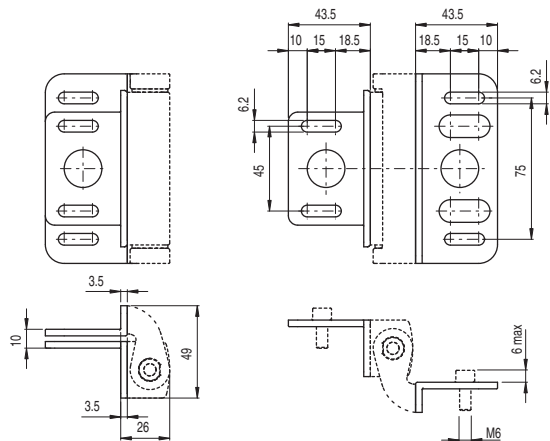

Article	Description	Article	Description	Article	Description
VF SFH3-C	Couple of plane plates for HP AA and HC AA supplied with fastening screws for attachment of the switch	VF SFH4-C	Couple of plane plates for HC LL supplied with fastening screws for attachment of the switch	VF SFH7	HP AB series mobile part cover in stainless steel

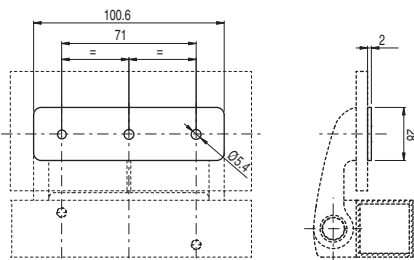
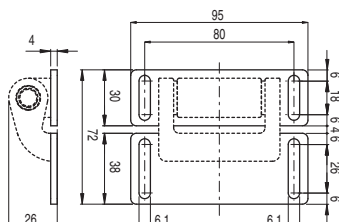
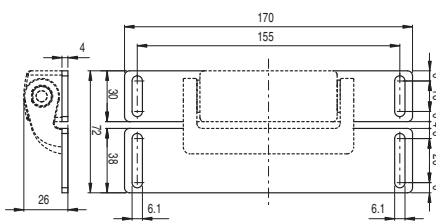
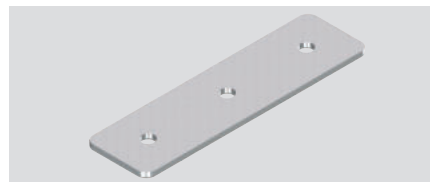

All values in the drawings are in mm

Accessories See page 359

→ The 2D and 3D files are available at www.pizzato.com